



3.3V CMOS 32-BIT BUFFER/ DRIVER WITH 3-STATE OUTPUTS AND BUS-HOLD

IDT74ALVCH32244

FEATURES:

- 0.5 MICRON CMOS Technology
- Typical $t_{sk(o)}$ (Output Skew) < 250ps
- ESD > 2000V per MIL-STD-883, Method 3015; > 200V using machine model (C = 200pF, R = 0)
- $V_{cc} = 3.3V \pm 0.3V$, Normal Range
- $V_{cc} = 2.7V$ to $3.6V$, Extended Range
- $V_{cc} = 2.5V \pm 0.2V$
- CMOS power levels (0.4μ W typ. static)
- Rail-to-Rail output swing for increased noise margin
- Available in 96-ball LFBGA package

DRIVE FEATURES:

- High Output Drivers: $\pm 24mA$
- Suitable for Heavy Loads

APPLICATIONS:

- 3.3V high speed systems
- 3.3V and lower voltage computing systems

DESCRIPTION:

This 32-bit buffer/driver is built using advanced dual metal CMOS technology. This high-speed, low power device offers bus/backplane interface capability with improved packing density. The device has a flow-through organization for simplifying board layout. The three-state controls operate this device in a Quad-Nibble, Dual-Byte or single 16-bit word mode. All inputs are designed with hysteresis for improved noise margin.

The ALVCH32244 has been designed with a $\pm 24mA$ output driver. This driver is capable of driving a moderate to heavy load while maintaining speed performance.

The ALVCH32244 has "bus-hold" which retains the inputs' last state whenever the input bus goes to a high impedance. This prevents floating inputs and eliminates the need for pull-up/down resistors.

FUNCTIONAL BLOCK DIAGRAM

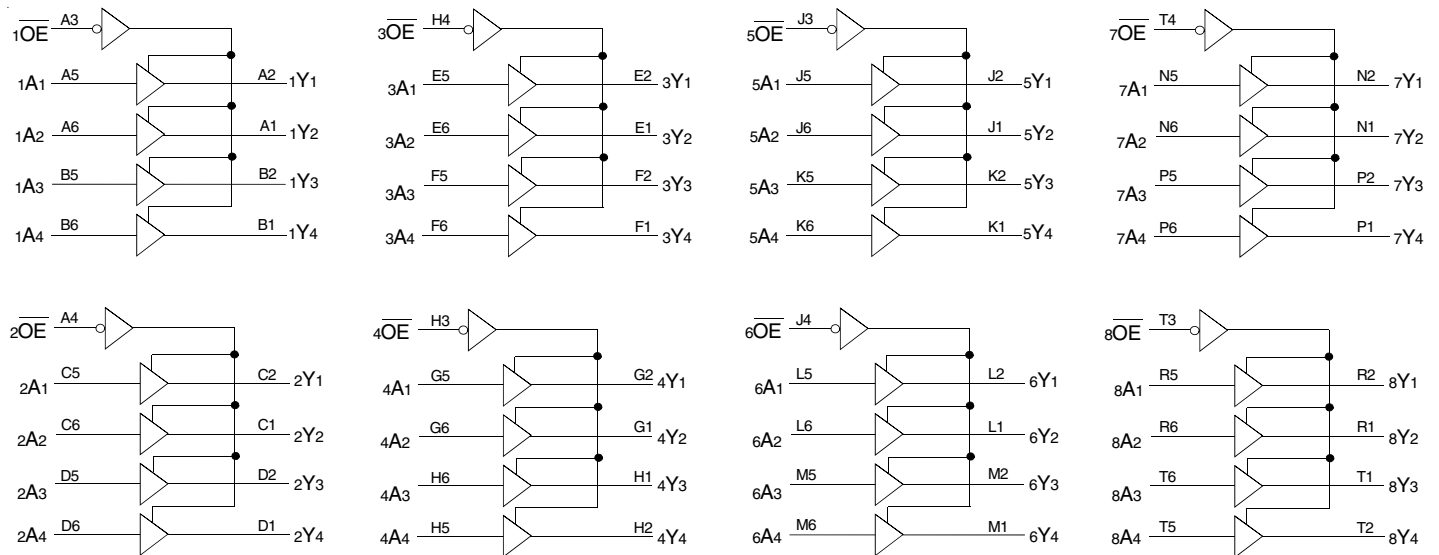

The IDT logo is a registered trademark of Integrated Device Technology, Inc.

PIN CONFIGURATION

6	1A2	1A4	2A2	2A4	3A2	3A4	4A2	4A3	5A2	5A4	6A2	6A4	7A2	7A4	8A2	8A3
5	1A1	1A3	2A1	2A3	3A1	3A3	4A1	4A4	5A1	5A3	6A1	6A3	7A1	7A3	8A1	8A4
4	$\overline{2OE}$	GND	VCC	GND	GND	VCC	GND	$\overline{3OE}$	$\overline{6OE}$	GND	VCC	GND	GND	VCC	GND	$\overline{7OE}$
3	$\overline{1OE}$	GND	VCC	GND	GND	VCC	GND	$\overline{4OE}$	$\overline{5OE}$	GND	VCC	GND	GND	VCC	GND	$\overline{8OE}$
2	1Y1	1Y3	2Y1	2Y3	3Y1	3Y3	4Y1	4Y4	5Y1	5Y3	6Y1	6Y3	7Y1	7Y3	8Y1	8Y4
1	1Y2	1Y4	2Y2	2Y4	3Y2	3Y4	4Y2	4Y3	5Y2	5Y4	6Y2	6Y4	7Y2	7Y4	8Y2	8Y3
	A	B	C	D	E	F	G	H	J	K	L	M	N	P	R	T

LFBGA
TOPVIEW

96 BALL LFBGA PACKAGE ATTRIBUTES

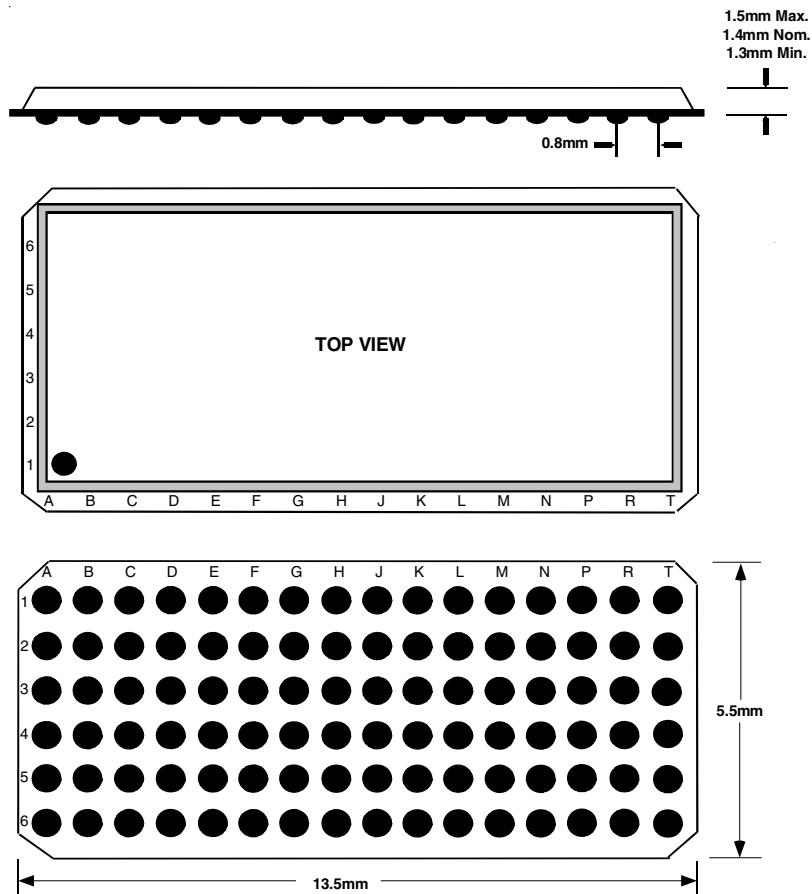

ABSOLUTE MAXIMUM RATINGS⁽¹⁾

Symbol	Description	Max	Unit
V _{TERM} ⁽²⁾	Terminal Voltage with Respect to GND	-0.5 to +4.6	V
V _{TERM} ⁽³⁾	Terminal Voltage with Respect to GND	-0.5 to V _{CC} +0.5	V
T _{STG}	Storage Temperature	-65 to +150	°C
I _{OUT}	DC Output Current	-50 to +50	mA
I _{IK}	Continuous Clamp Current, V _i < 0 or V _i > V _{CC}	±50	mA
I _{OK}	Continuous Clamp Current, V _o < 0	-50	mA
I _{CC} I _{SS}	Continuous Current through each V _{CC} or GND	±100	mA

NOTES:

1. Stresses greater than those listed under ABSOLUTE MAXIMUM RATINGS may cause permanent damage to the device. This is a stress rating only and functional operation of the device at these or any other conditions above those indicated in the operational sections of this specification is not implied. Exposure to absolute maximum rating conditions for extended periods may affect reliability.
2. V_{CC} terminals.
3. All terminals except V_{CC}.

CAPACITANCE (T_A = +25°C, F = 1.0MHz)

Symbol	Parameter ⁽¹⁾	Conditions	Typ.	Max.	Unit
C _{IN}	Input Capacitance	V _{IN} = 0V	5	7	pF
C _{OUT}	Output Capacitance	V _{OUT} = 0V	7	9	pF
C _{I/O}	I/O Port Capacitance	V _{IN} = 0V	7	9	pF

NOTE:

1. As applicable to the device type.

PIN DESCRIPTION

Pin Names	Description
\overline{xOE}	3-State Output Enable Inputs (Active LOW)
xAx	Data Inputs ⁽¹⁾
xYx	3-State Outputs

NOTE:

1. These pins have "Bus-Hold". All other pins are standard inputs, outputs, or I/Os.

FUNCTION TABLE (EACH 4-BIT BUFFER)⁽¹⁾

Inputs		Outputs
\overline{xOE}	xAx	xYx
L	H	H
L	L	L
H	X	Z

NOTE:

1. H = HIGH Voltage Level
L = LOW Voltage Level
X = Don't Care
Z = High Impedance

DC ELECTRICAL CHARACTERISTICS OVER OPERATING RANGE

Following Conditions Apply Unless Otherwise Specified:

Operating Condition: $T_A = -40^{\circ}\text{C}$ to $+85^{\circ}\text{C}$

Symbol	Parameter	Test Conditions		Min.	Typ. ⁽¹⁾	Max.	Unit
V _{IH}	Input HIGH Voltage Level	V _{CC} = 2.3V to 2.7V		1.7	—	—	V
		V _{CC} = 2.7V to 3.6V		2	—	—	
V _{IL}	Input LOW Voltage Level	V _{CC} = 2.3V to 2.7V		—	—	0.7	V
		V _{CC} = 2.7V to 3.6V		—	—	0.8	
I _{IH}	Input HIGH Current	V _{CC} = 3.6V	V _I = V _{CC}	—	—	±5	μA
I _{IL}	Input LOW Current	V _{CC} = 3.6V	V _I = GND	—	—	±5	μA
I _{OZH} I _{OZL}	High Impedance Output Current (3-State Output pins)	V _{CC} = 3.6V	V _O = V _{CC}	—	—	±10	μA
			V _O = GND	—	—	±10	
V _{IK}	Clamp Diode Voltage	V _{CC} = 2.3V, I _{IN} = -18mA		—	-0.7	-1.2	V
V _H	Input Hysteresis	V _{CC} = 3.3V		—	100	—	mV
I _{CC1} I _{CC2} I _{CC3}	Quiescent Power Supply Current	V _{CC} = 3.6V V _{IN} = GND or V _{CC}		—	0.1	40	μA
ΔI _{CC}	Quiescent Power Supply Current Variation	One input at V _{CC} - 0.6V, other inputs at V _{CC} or GND		—	—	750	μA

NOTE:

1. Typical values are at V_{CC} = 3.3V, +25°C ambient.

BUS-HOLD CHARACTERISTICS

Symbol	Parameter ⁽¹⁾	Test Conditions		Min.	Typ. ⁽²⁾	Max.	Unit
I _{BHH} I _{BHL}	Bus-Hold Input Sustain Current	V _{CC} = 3V	V _I = 2V	-75	—	—	μA
			V _I = 0.8V	75	—	—	
I _{BHH} I _{BHL}	Bus-Hold Input Sustain Current	V _{CC} = 2.3V	V _I = 1.7V	-45	—	—	μA
			V _I = 0.7V	45	—	—	
I _{BHHO} I _{BHLO}	Bus-Hold Input Overdrive Current	V _{CC} = 3.6V	V _I = 0 to 3.6V	—	—	±500	μA

NOTES:

1. Pins with Bus-Hold are identified in the pin description.
2. Typical values are at V_{CC} = 3.3V, +25°C ambient.

OUTPUT DRIVE CHARACTERISTICS

Symbol	Parameter	Test Conditions ⁽¹⁾		Min.	Max.	Unit
VOH	Output HIGH Voltage	VCC = 2.3V to 3.6V	IOH = - 0.1mA	VCC - 0.2	—	V
		VCC = 2.3V	IOH = - 6mA	2	—	
		VCC = 2.3V	IOH = - 12mA	1.7	—	
		VCC = 2.7V		2.2	—	
		VCC = 3V		2.4	—	
		VCC = 3V	IOH = - 24mA	2	—	
VOL	Output LOW Voltage	VCC = 2.3V to 3.6V	IOH = 0.1mA	—	0.2	V
		VCC = 2.3V	IOH = 6mA	—	0.4	
			IOH = 12mA	—	0.7	
		VCC = 2.7V	IOH = 12mA	—	0.4	
		VCC = 3V	IOH = 24mA	—	0.55	

NOTE:
1. VIH and VIL must be within the min. or max. range shown in the DC ELECTRICAL CHARACTERISTICS OVER OPERATING RANGE table for the appropriate VCC range. TA = - 40°C to + 85°C.

OPERATING CHARACTERISTICS, TA = 25°C

Symbol	Parameter	Test Conditions	VCC = 2.5V ± 0.2V	VCC = 3.3V ± 0.3V	Unit
			Typical	Typical	
CPD	Power Dissipation Capacitance per Driver Outputs enabled	CL = 0pF, f = 10Mhz	32	38	pF
CPD	Power Dissipation Capacitance per Driver Outputs disabled		8	10	

SWITCHING CHARACTERISTICS⁽¹⁾

Symbol	Parameter	VCC = 2.5V ± 0.2V		VCC = 2.7V		VCC = 3.3V ± 0.3V		Unit
		Min.	Max.	Min.	Max.	Min.	Max.	
tPLH	Propagation Delay	1	3.7	—	3.6	1	3	ns
tPHL	xAX to xYx							
tPZH	Output Enable Time	1	5.7	—	5.4	1	4.4	ns
tPZL	xOE to xYx							
tPHZ	Output Disable Time	1	5.2	—	4.6	1	4.1	ns
tPLZ	xOE to xYx							
tSK(O)	Output Skew ⁽²⁾	—	—	—	—	—	500	ps

NOTES:
1. See TEST CIRCUITS AND WAVEFORMS. TA = - 40°C to + 85°C.
2. Skew between any two outputs of the same package and switching in the same direction.

TEST CIRCUITS AND WAVEFORMS

TEST CONDITIONS

Symbol	V _{CC} ⁽¹⁾ = 3.3V±0.3V	V _{CC} ⁽¹⁾ = 2.7V	V _{CC} ⁽²⁾ = 2.5V±0.2V	Unit
V _{LOAD}	6	6	2 x V _{CC}	V
V _{IH}	2.7	2.7	V _{CC}	V
V _T	1.5	1.5	V _{CC} / 2	V
V _{LZ}	300	300	150	mV
V _{HZ}	300	300	150	mV
C _L	50	50	30	pF

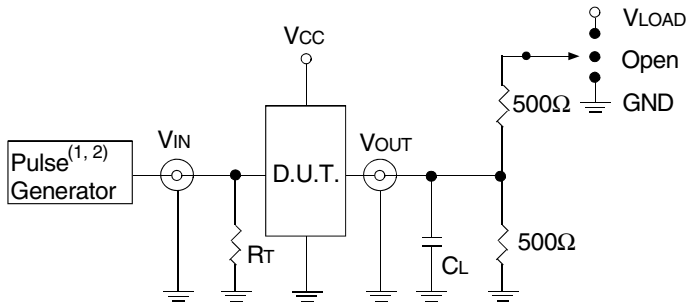

Test Circuit for All Outputs

DEFINITIONS:

C_L = Load capacitance: includes jig and probe capacitance.
R_T = Termination resistance: should be equal to Z_{OUT} of the Pulse Generator.

NOTES:

1. Pulse Generator for All Pulses: Rate ≤ 1.0MHz; t_r ≤ 2.5ns; t_r ≤ 2.5ns.
2. Pulse Generator for All Pulses: Rate ≤ 1.0MHz; t_r ≤ 2ns; t_r ≤ 2ns.

SWITCH POSITION

Test	Switch
Open Drain Disable Low Enable Low	V _{LOAD}
Disable High Enable High	GND
All Other Tests	Open

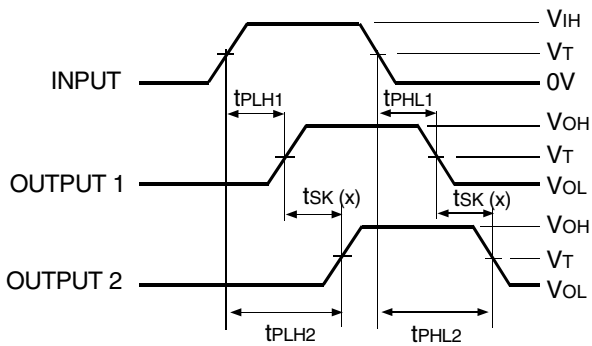

$$tsk(x) = |t_{PLH2} - t_{PLH1}| \text{ or } |t_{PHL2} - t_{PHL1}|$$

Output Skew - tsk(x)

NOTES:

1. For tsk(o) OUTPUT1 and OUTPUT2 are any two outputs.
2. For tsk(b) OUTPUT1 and OUTPUT2 are in the same bank.

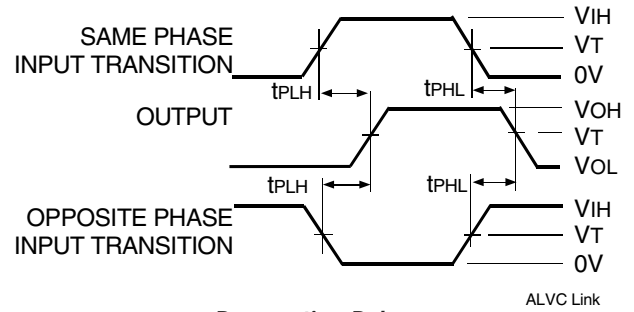

Propagation Delay

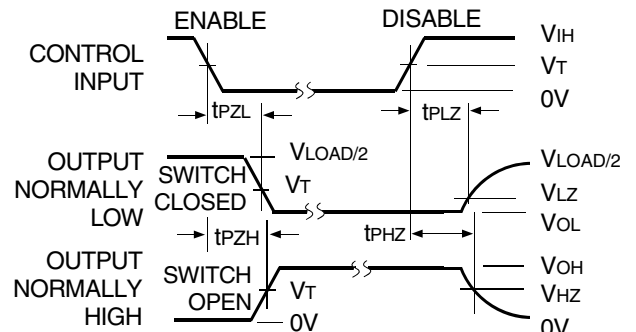

Enable and Disable Times

NOTE:

1. Diagram shown for input Control Enable-LOW and input Control Disable-HIGH.

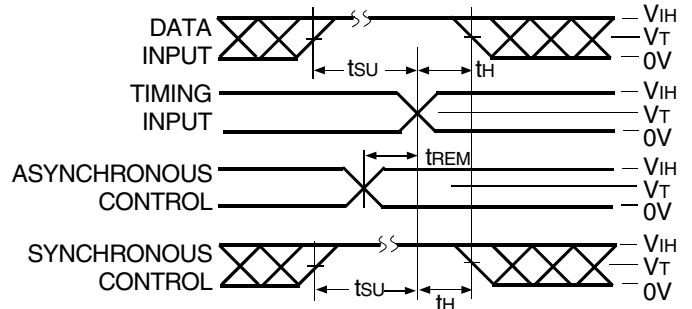

Set-up, Hold, and Release Times

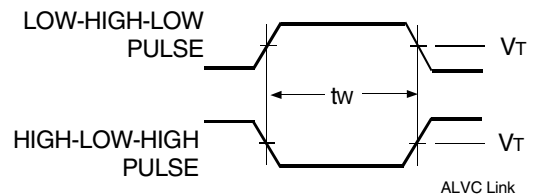

Pulse Width

ORDERING INFORMATION

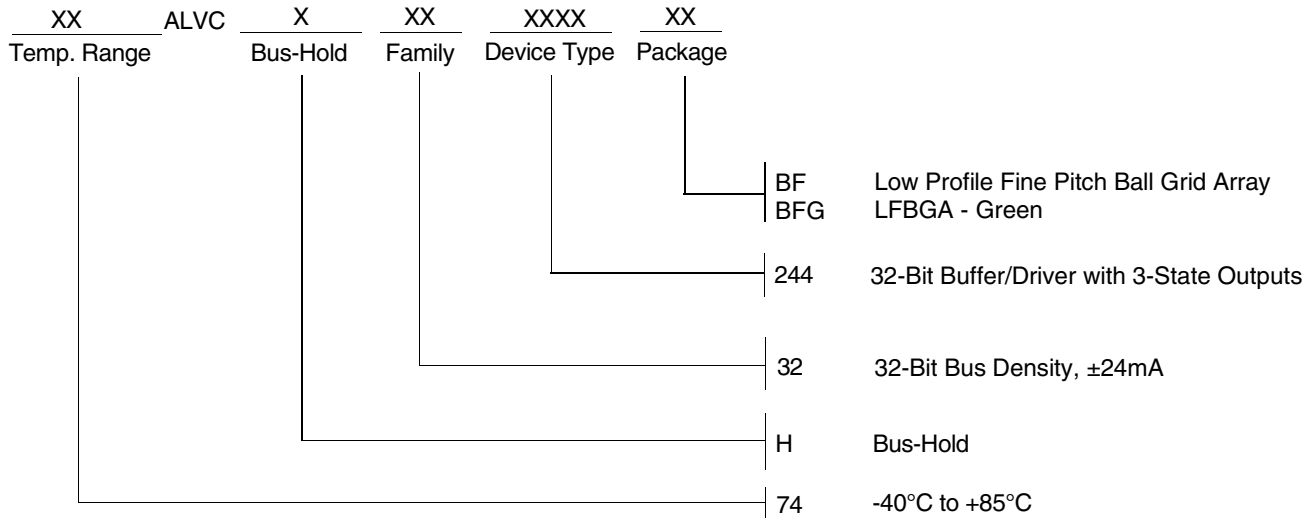

CORPORATE HEADQUARTERS
6024 Silver Creek Valley Road
San Jose, CA 95138

for SALES:
800-345-7015 or 408-284-8200
fax: 408-284-2775
www.idt.com

for Tech Support:
logichelp@idt.com